

XE-C SERIES

ELECTRIC SELF-PROPELLED SCISSOR LIFTS

Mantall®

Standard Features

- Manual emergency lower system
- Platform swing gate
- Extended platform
- Foldable platform
- Multi-disc wet brake
- Manual brake release
- Pothole protection
- Non-marking tires
- AC power to platform
- Tilt alarm
- Buzzer
- Safety brackets
- Charging indicator
- Forklift pockets
- Diagnosis system
- Maintenance free battery
- Dual flashing beacon

Options Features

- Air line to platform
- Power socket to platform
- Platform work light
- Overload sensor
- Horn
- Anti-collision system
- Top limit protection auto-stop device
- Motion Alarm



XE-C SERIES

MODEL	XE80C	XE100C
Working height max H1	8 m	10 m
Platform height max H2	6 m	8 m
Length - Platform extension	1 m	
Lifting capacity	350 kg	230 kg
Lift capacity on the extension	120 kg	
Dimension of the platform B x C x A	2.25 x 0.8 x 1.1 m	
Platform length - extended K	3.2 m	
Platform skirting board height L	0.15 m	
Overall length and width E x F	2.5 x 0.8 m	
Height stowed D	2.17 m	2.3 m
Height - guardrails folded M	1.72 m	1.86 m
Wheelbase G	1.85 m	
Ground clearance H	0.1 m	
Ground clearance - deployed potholes	0.019 m	
Turning radius - inside	0	
Turning radius - outside	2.12 m	
Rising time / lowering time	27 / 29 s	35 / 17 s
Drive speed - stowed	3.4 km/h	
Drive speed - raised	0.7 km/h	
Gradeability	30%	25%
Tilt sensor - front to back	3°	
Tilt sensor - side to side	2°	
Drive model	Hydraulic / Electric	
Hydraulic tank capacity	15 L	
Tire size	356 x 114 x 254 mm	
Max. platform occupancy	2 pers	
Power source	24 V / 225Ah	
Weight - ANSI/CSA Standard	1690 kg	1855 kg
- CE/AUS Standard	1910 kg	2000 kg

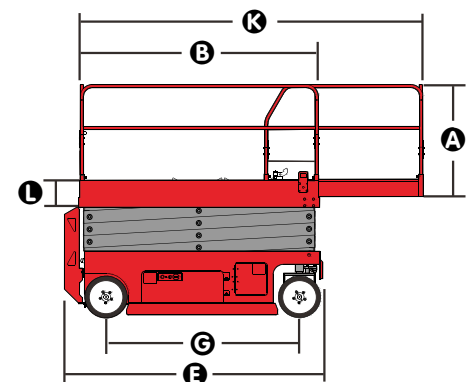
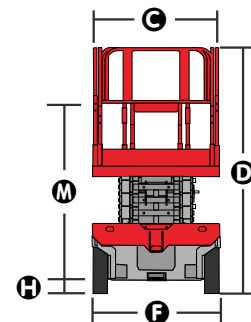
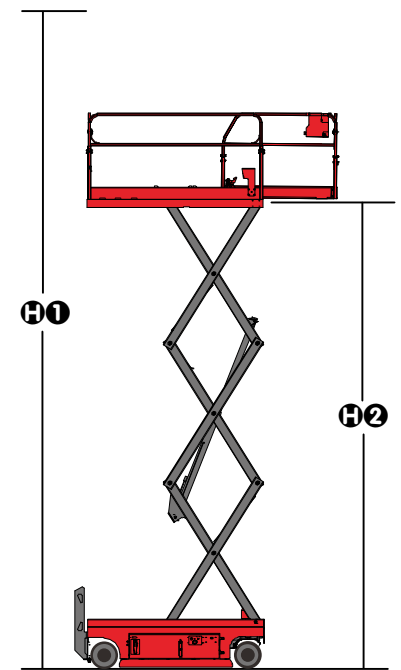

» Mantall provides user with both hydraulic drive (HD) and electrical drive (ED) walking modes, in order to meet the demands of different customers.